

CONEXIONES Y VÁLVULAS RUD

TAPAS CIEGAS

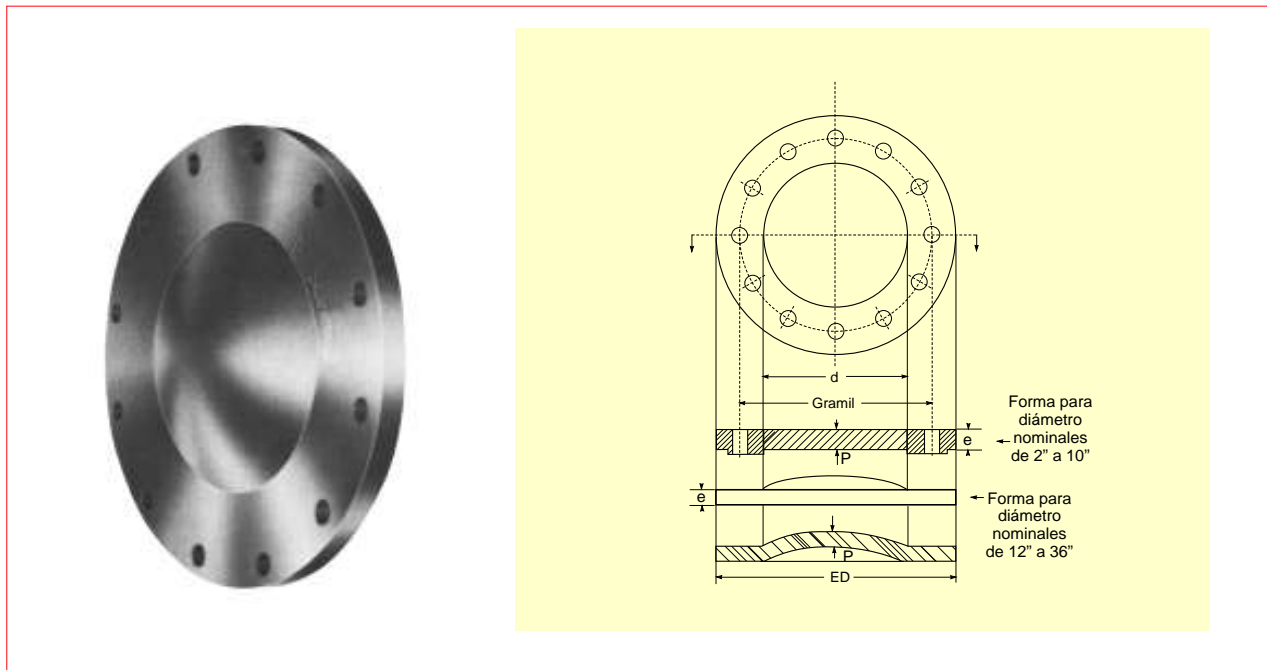

ESPECIFICACIONES SEGUN AWWA C-110

DIÁMETRO NOMINAL d		DIÁMETRO DE LA BRIDA ED		ESPESOR MÍNIMO DE LA BRIDA e		ESPESOR DE LA PARED P		PESO APROX.
mm	plg	mm	plg	mm	plg	mm	plg	Kg
50.8	2	152.4	6	15.9	5/8	14.3	9/16	2.0
63.5	2 1/2	177.8	7	17.5	11/16	15.9	5/8	3.0
76.2	3	190.5	7 1/2	19.1	3/4	17.5	11/16	3.7
101.6	4	228.6	9	23.8	15/16	22.2	7/8	6.5
152.4	6	279.4	11	25.4	1	23.8	15/16	10.5
203.2	8	342.9	13 1/2	28.6	1 1/8	27.0	1 1/16	18.0
254.0	10	406.4	16	30.2	1 3/16	28.6	1 1/8	26.3
304.8	12	482.6	19	31.8	1 1/4	20.6	13/16	35.8
355.6	14	533.4	21	34.9	1 3/8	22.2	7/8	46.8
406.4	16	596.9	23 1/2	36.5	1 7/16	25.4	1	62.5
457.2	18	635.0	25	39.7	1 9/16	27.0	1 1/16	74.7
508.0	20	698.5	27 1/2	42.9	1 11/16	28.6	1 1/8	96.5
609.6	24	812.8	32	47.6	1 7/8	31.8	1 1/4	144.1
762.0	30	984.3	38 3/4	54.0	2 1/8	36.5	1 7/16	238.4
914.4	36	1168.4	46	60.3	2 3/6	41.3	1 5/8	373.4
1066.8	42	1346.2	53	66.7	2 5/8	44.5	1 3/4	650.0

NOTA: Se surten con taladro y rosca NPT a solicitud.